

SOLAR.SEED

Solar Powered Pump Systems

The consortium consists of three partners:

HARTMANN
ELEKTROTECHNIK

KSB 

 **mp|tec**

Solar powered pump system as a holistic solution

Individually planned solar powered pump systems for large-scale plants (alternating current system)

The demand for water and energy will continue to rise in the coming decades due to the constantly growing population and economy. Therefore, sustainable and decentralized irrigation and water supply systems are becoming increasingly important to provide people with drinking water, especially in agriculture and areas with a poor infrastructure.

Without a permanent, efficient and reliable water supply, progress and development will be impossible. Solar-powered pump and irrigation systems can be applied in any part of the world to provide water. Additionally, SOLAR.SEED is not only applicable in the field of agriculture and pasture farming but also for drinking water supply, sewage treatment, tourism and pisciculture.

Depending on the project requirements, solar powered pump systems can be implemented for the support of portable water or treatment of waste water with the solar powered complete system. In this context we rely on the power of solar energy through the use of photovoltaics and innovative energy converter. An intelligent solar pump inverter convinces with its excellent features. The solar pump inverter features class-leading characteristics, for instance the high performance frequency inverter optimizes the photovoltaic installation's energy production and guarantees efficient control of the water pump. It controls the pump according to the available amount of sunlight.

Benefits at a glance

- Fully extensive solar pump system including comprehensive project planning, components and installation of the systems
- Complete system "Made and Engineered in Germany"
- Easy installation of the overall system
- Requires little maintenance
- More efficient in comparison to fossil powered generators
- Electricity grid not necessary
- Reliable, efficient and durable system
- No noise nuisance and CO2 emission

The customized solar pump complete systems can ensure a stable and reliable supply of potable water through the use of off-grid photovoltaic systems. It is inexpensive and fully self-sufficient, without batteries and any disturbing power lines.

Constructing a solar powered complete pump system, customized to specific needs, requires a high level of technical expertise, experience and interdisciplinary skills. Therefore, mp-tec works closely with prestigious partners like KSB AG, a leading international manufacturer of pumps and valves and HARTMANN ELEKTROTECHNIK, a well-known supplier of electrical engineering services and electrical equipment's.

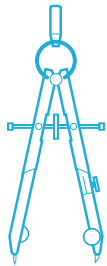

01

SYSTEM ENGINEERING

by mp-tec

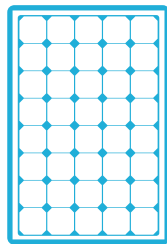

02

SOLAR MODULES

e.g. mp-tec S.LINE

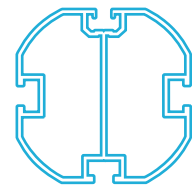

03

MOUNTING SYSTEM

mp-tec QUICK.LINE

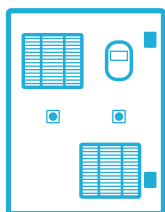

04

**PUMP MANAGEMENT AND
SOLAR PUMP INVERTER**

by HARTMANN ELEKTROTECHNIK

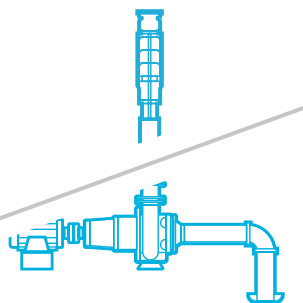

05

**WATER PUMP OR
CENTRIFUGAL PUMP**

by KSB

+
We make sure,
water gets to where
it's needed

Solar submersible pump system

The standard solution for small-scale plants
(direct current system)

The solar submersible pump system is used to deliver ground water independently and off-grid. With its modular construction, the individual components can be adapted to meet all requirements and application areas. By using subsurface pump system, a reliable and sustainable water supply is ensured without any grid connection. The system is designed for continuous and short operation and thus particularly suitable for water supply installations in remote locations

Features

- High stability and long life span of the complete system
- Irradiation angle infinitely adjustable
- Weight optimization and avoidance of rusting through the use of aluminum
- Solar module installation with the long-time optimally proven mounting system QUICK.LINE by mp-tec
- Easy installation and periodic maintenance of the pumps
- Material of all pump types: stainless steel
- Pump with dry-run protection, over- and under voltage protection as well as over temperature protection
- Variable installation on roofs, water tanks or foundation
- *Optional: water storage system*

The delivery rate depends on the delivery head and the installed power and varies according to the type of the pump.

	Solarpumpe 300	Solarpumpe 500	Solarpumpe 800	Solarpumpe 1000	Solarpumpe 1300
Delivery head	Delivery output in m³/h				
15 m	1.4 – 2.5	5.0 – 5.8	6.5 – 9.0	7.6 – 11.9	8.4 – 13.9
45 m	0.2 – 1.2	1.2 – 2.5	2.4 – 2.7	3.7	4.1 – 4.6
90 m	0.1 – 0.6	1.0 – 1.3	1.8	2.5	---

The solar submersible pump system consists of following components

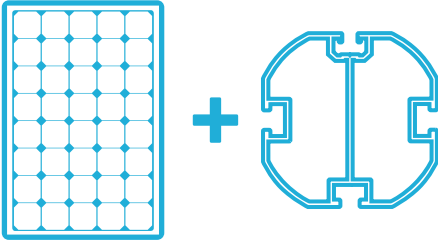

VARIABLE CONSTRUCTION
for different number of modules and angles

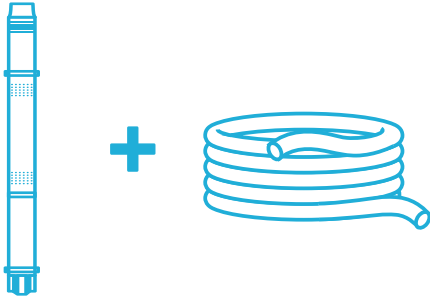

SUBMERSIBLE PUMP*
with polyethylene pipe 25,32,40 (PE-HD drinking water)

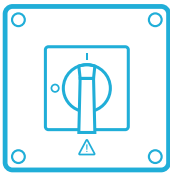

DISCONNECTOR
incl. lock

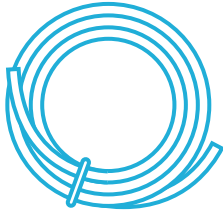

UNDERWATER CABLES
including grounding conductor

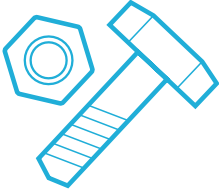

EQUIPMENT
corrosion-resistant steel cable, electrical connection terminals, screwed connections, shrinkable tubing set

*The system make use of standard pumps, not pumps from KSB.

The solar submersible pump system is available in 5 performance classes

Solarpumpe 300	265 Wp / 1 Modul	Solarpumpe 1000	1.060 Wp / 4 Module
Solarpumpe 500	530 Wp / 2 Module	Solarpumpe 1300	1.325 Wp / 5 Module
Solarpumpe 800	795 Wp / 3 Module		

For a request and any further information please contact us:

We offer professional advice from the expertise for the right system of your power requirements. Detailed information on the innovative benefits offered:

www.mp-tec.de

for photovoltaics and mounting systems

www.ksb.com

for pumps and valves

www.hartmannhamburg.de

for electrical solutions

PUBLISHER

mp-tec GmbH & Co. KG

Copyright by mp-tec © 2016

3rd Edition 03/2016

phone: +49 (0) 33 34 59 44 - 50 10

fax: +49 (0) 33 34 59 44 - 15

info@solar-seed.com

www.solar-seed.com